

Vacuum Feedthroughs

These feedthroughs are designed for the use with fiber-optics in vacuum chambers, such as for plasma and coating deposition monitoring. They can be used in chambers with wall thicknesses of 5-40 mm and vacuum levels up to 10^{-7} millibar.

The feedthrough assembly consists of an M12 housing with Viton® O-ring and two SMA fiber-optic interconnects to allow easy coupling to fiber-optic cables and probes. In order to connect these assemblies to fiber-optic cables inside/outside the chamber, two extra SMA fiber

interconnects (ME-FI-SM-MM) should be ordered separately.

The vacuum feedthrough can be delivered for all fiber diameters, from 50µm up to 1000 µm for UV/VIS/NIR.

A high temperature version of the vacuum feedthrough(-HT) is also available enabling the device to withstand temperatures up to 200°C.



FC-VFT

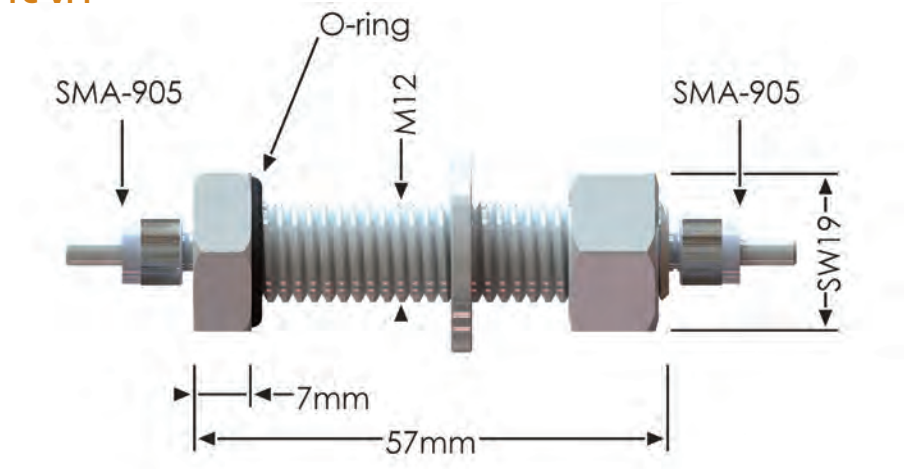

Technical Data

Fibers	1 fiber, diameter 50 µm, 100 µm, 200 µm, 400 µm, 600 µm, 800 µm or 1000 µm
Wavelength range	200-800 nm (UV/VIS), 350-2500 (VIS/NIR) or 200-2500 nm (UV/VIS/NIR)
Connectors	Standard SMA-905 connectors (2x)
Wall thickness of vacuum chamber	5-40 mm
Vacuum	Max. 10^{-7} mbar
Temperature	-40°C to 100°C (-HT version 200°C)

Ordering Information

FC-VFT-xx50	• Vacuum feedthrough for 50 µm fibers, incl. SMA adapter, needs 2 extra SMA interconnects
FC-VFT-UVIR100	• As FC-VFT-xx50, for 100 µm broadband fibers
FC-VFT-UVIR200	• As FC-VFT-xx50, for 200 µm broadband fibers
FC-VFT-UVIR400	• As FC-VFT-xx50, for 400 µm broadband fibers
FC-VFT-UVIR600	• As FC-VFT-xx50, for 600 µm broadband fibers
FC-VFT-xx800	• As FC-VFT-xx50, for 800 µm fibers
FC-VFT-xx1000	• As FC-VFT-xx50, for 1000 µm fibers
ME-FI-SM-MM	• SMA fiber interconnect, 2 pieces needed for each vacuum feedthrough

Specify xx = UV for UV/VIS fiber cables, IR for VIS/NIR

Options

-HT	• High Temperature version (up to 200°C)
------------	--